

SD Card Adapter for microSD™ card

SCHC Series

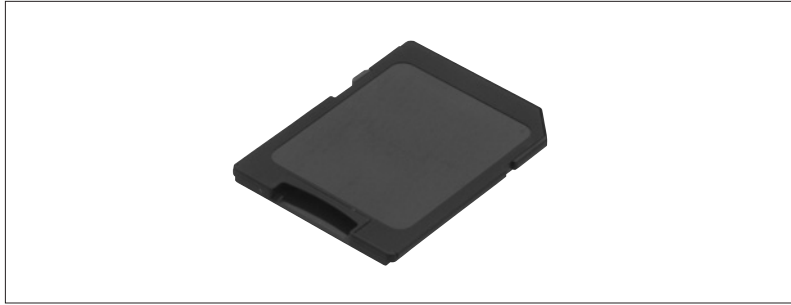

High contact reliability and locking mechanism work effectively to prevent unintentional ejection of cards.



Features

- General SD card hosts can be used by inserting miniSD™ card into the adaptor.
- Unique half-lock structure stops media from flying out during ejection.

Applications

- For digital still cameras, digital camcorders, mobile phones, PCs and personal digital assistants

Typical Specifications

Items		Specifications
Structure	Applicable media	microSD™ Card
	Mounting type	_____
	Mounting style	_____
	Media ejection structure	Manual insertion/removal
Performance	Operating temperature range	-25°C to +85°C
	Voltage proof	500V AC 1minute
	Insulation resistance (Initial)	1,000MΩ min.
	Contact resistance (Initial)	100mΩ max.
	Insertion and removal cycle	10,000cycles

Product Line

Media ejection structure	Packing system	Product No.
Manual insertion/removal	Tray	SCHC1A0200

For SD Memory Card

For miniSD™ Card

For microSD™ Card

For W-SIM

For Memory Stick Micro™

For Memory Stick™

Combine Type

For Compact Flash™

For PC cards supporting CardBus

For Express Card™

For CMOS Camera Module

Dimensions

Unit:mm

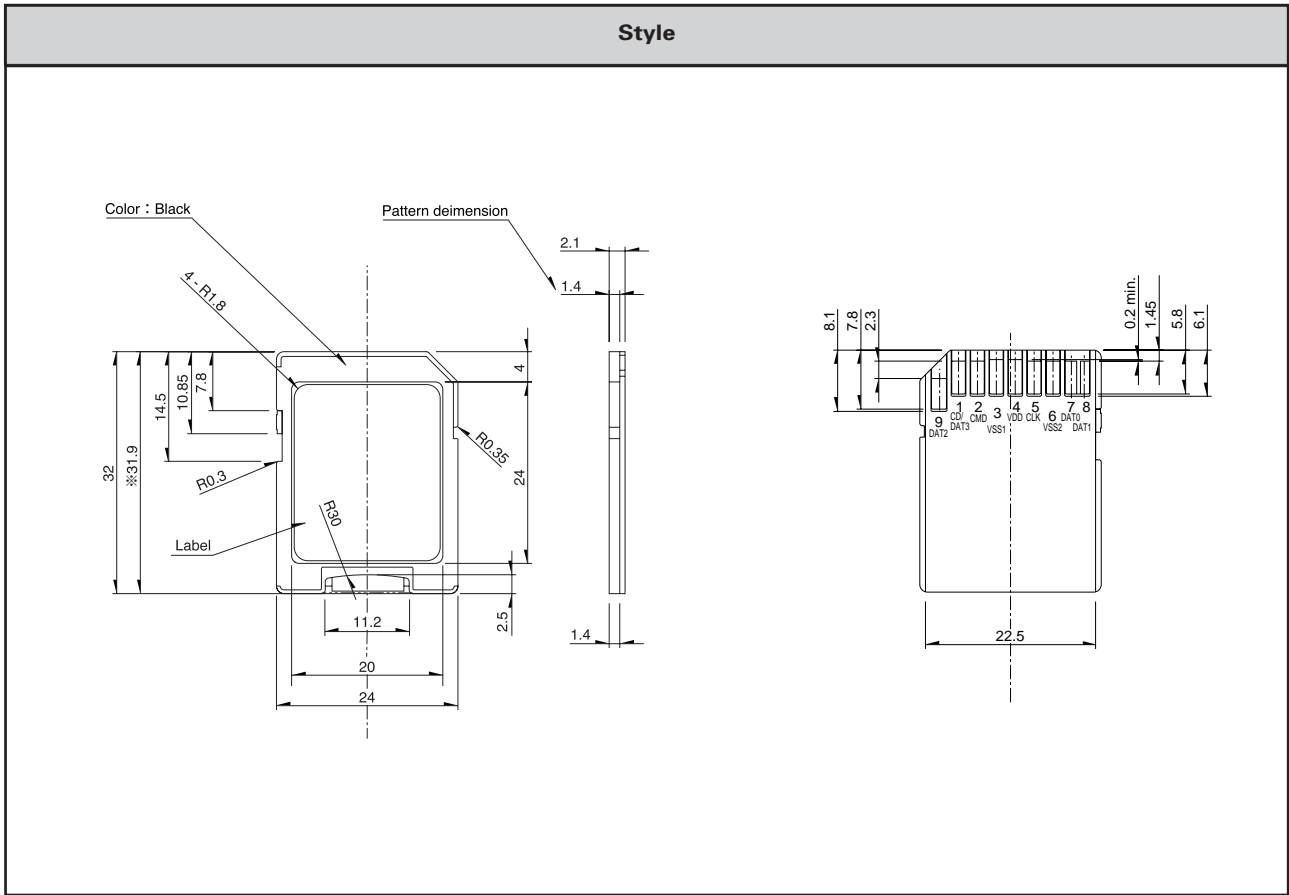

- For SD Memory Card
- For miniSD™ Card
- For microSD™ Card
- For W-SIM
- For Memory Stick Micro™
- For Memory Stick™
- Combine Type
- For Compact Flash™
- For PC cards supporting CardBus
- For Express Card™
- For CMOS Camera Module

Note

※ Above dimensions apply when a microSD™ card is fully inserted into the adapter case. Label indications will be customized independently. Samples will be delivered without a label.

Cautions

1. This product has been designed and manufactured for use in ordinary electronic equipment, such as AV equipment, electric home appliances, office machines and communication equipment. In case of using the products for highly sensitive applications such as medical, aviation, aerospace and security, the set makers shall require to include measures necessary to meet product safety requirements of such specific applications. Such measure may include additional protection circuits and redundant circuits, for example.
2. To prevent contact failures caused by sulfuration or oxidation on the contact and terminal or deterioration of solderability caused by film forming, please follow the instructions given below.
 - (1) Do not store the product in locations with high temperature or high humidity. Keep it in an atmosphere free from corrosive gases including sulphurous or chlorinate gas. Do not stack.
 - (2) Store the adapter unopened at room temperature and Low humidity. Use the product preferably within 3 months after delivery or within 6 months at the latest.
 - (3) To store the product after opening the package, keep it in a sealed polyethylene bag. Store in a dark, cool place, out of direct sunlight. Use the product as soon as possible.